

NIO 200 Series

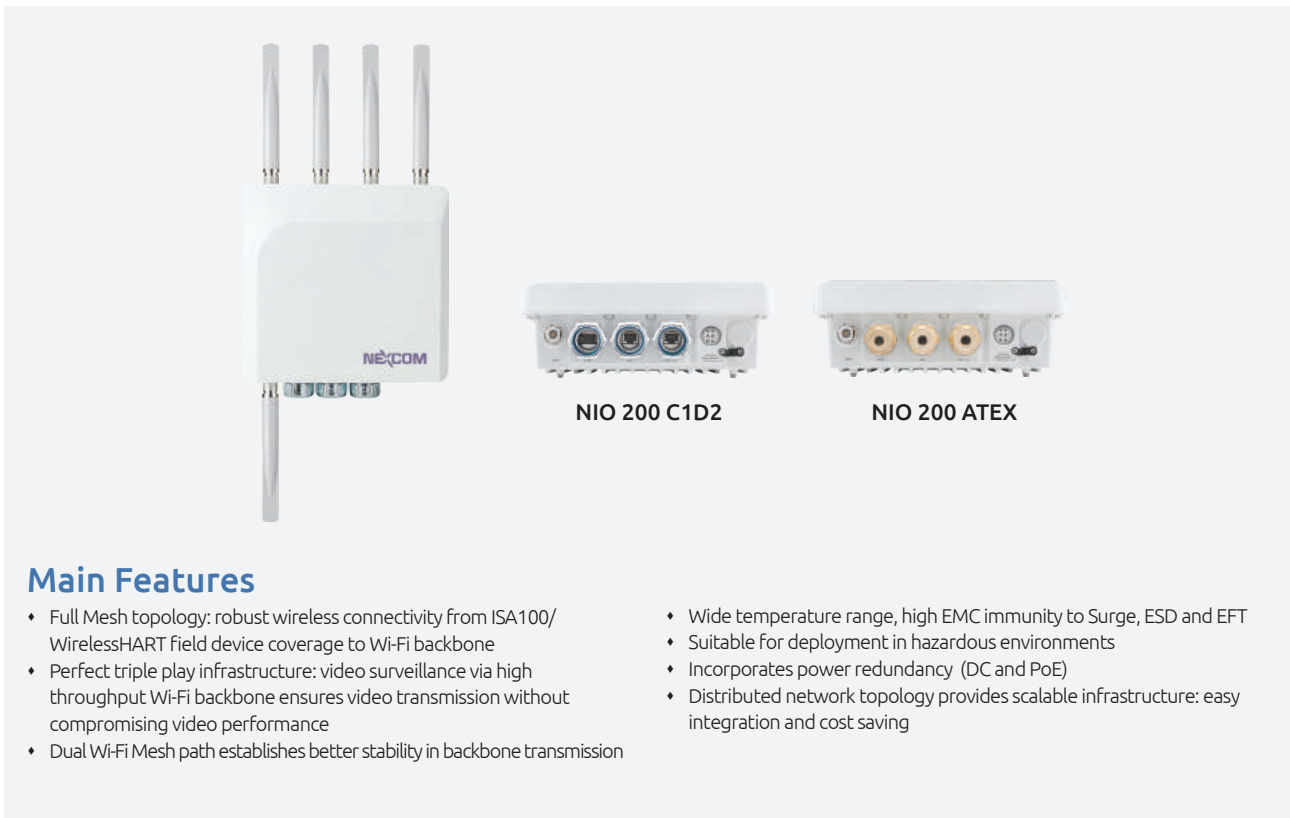

Main Features

- Full Mesh topology: robust wireless connectivity from ISA100/WirelessHART field device coverage to Wi-Fi backbone
- Perfect triple play infrastructure: video surveillance via high throughput Wi-Fi backbone ensures video transmission without compromising video performance
- Dual Wi-Fi Mesh path establishes better stability in backbone transmission
- Wide temperature range, high EMC immunity to Surge, ESD and EFT
- Suitable for deployment in hazardous environments
- Incorporates power redundancy (DC and PoE)
- Distributed network topology provides scalable infrastructure: easy integration and cost saving

Product Overview

NEXCOM NIO 200 is a powerful distributed network topology ISA100.11a access point integrating 802.11n Mesh technology. With ISA100.11a/WirelessHART technology, NIO 200 can establish fully Mesh network to ensure robust and reliable communication for mission-critical industrial wireless applications. The integration of both 802.11n Mesh & ISA100.11a/WirelessHART technology gives a full Mesh infrastructure from field devices to Wi-Fi backbone, thus a concrete wireless connectivity can be assured. It's designed to meet CID2 and ATEX certified requirement and is perfect solution to critical data monitoring and sensing in oil & gas, chemical plant, etc...

Specifications

Wireless Radio

- IEEE802.11a/n x 2, MIMO 2 x 2 • IEEE802.15.4, 1 Tx, 1 Rx

Wi-Fi Frequency Ranges

- USA: 5.15~5.25 GHz, 5.725~5.825 GHz • Europe: 5.47~5.725 GHz

RF Output Power: IEEE 802.11a

- 802.11a - 28 dBm with 2 antennas
- 802.11n (HT20) - 27 dBm with 2 antennas
- 802.11n (HT40) - 27 dBm with 2 antennas

* Note:

The available RF output power will be given by certified power in different region

Hardware

- WAN: 10/100/1000 Base-TX MDI/MDIX
- LAN: 10/100/1000 Base-TX MDI/MDIX
- Ethernet compliant with:
 - IEEE802.3/802.3u
 - Hardware based 10/100/1000, full/half, flow control auto negotiation
- Push buttons: 1 x reset/restore to default
- LED: - 2 x Ethernet - 2 x 11n radio
 - 1 x IWSN radio - 1 x Power/Status
- N-Type:
 - 5 x N-type connector for NIO 200IDR/IAG/HAG
 - 4 x N-type connector for NIO 200IDG

Safety Compliance

- UL 60950-1; 60950-22 • IEC 60950, 2nd edition
- EN 60950, 2nd edition • IEC 61000-4-2 level 4 ESD immunity

- IEC 61000-4-5 level 4 AC surge immunity
- IEC 61000-4-4 level 4 electrical fast transient burst immunity

Wi-Fi Security (AP Mode)

- WEP (64/128/152) • WAP/WPA2 mixed
- WPA2-personal (PSK+CCMP/AES) • Hidden ESSID support
- MAC address filtering (MAC ACL) • Station isolation
- * Note: The AP function is to be equipped in 2nd phase stage.

System Management

- nCare, web GUI management • SNMP V1/V2c/V3
- Event log • Syslog information support
- Configuration backup and restore
- One-button-click to restore factory default setting
- Firmware upgrade • SNMP V1/V2c/V3 client

High-Side Communication Interfaces

- Monitoring and Control System (MCS)
- MODBUS/TCP
- Gateway Services Access Point (GSAP) (only for NIO200IAG/IDG)
- HART-IP (only for NIO200HAG)

Physical and Power

- 12~48 VDC PoE (standard PoE 802.3at)
- Wall/pole mountable
- Dimension: 256mm x 226mm x 91mm
- Weight: 2.5Kg

Dimension Drawing

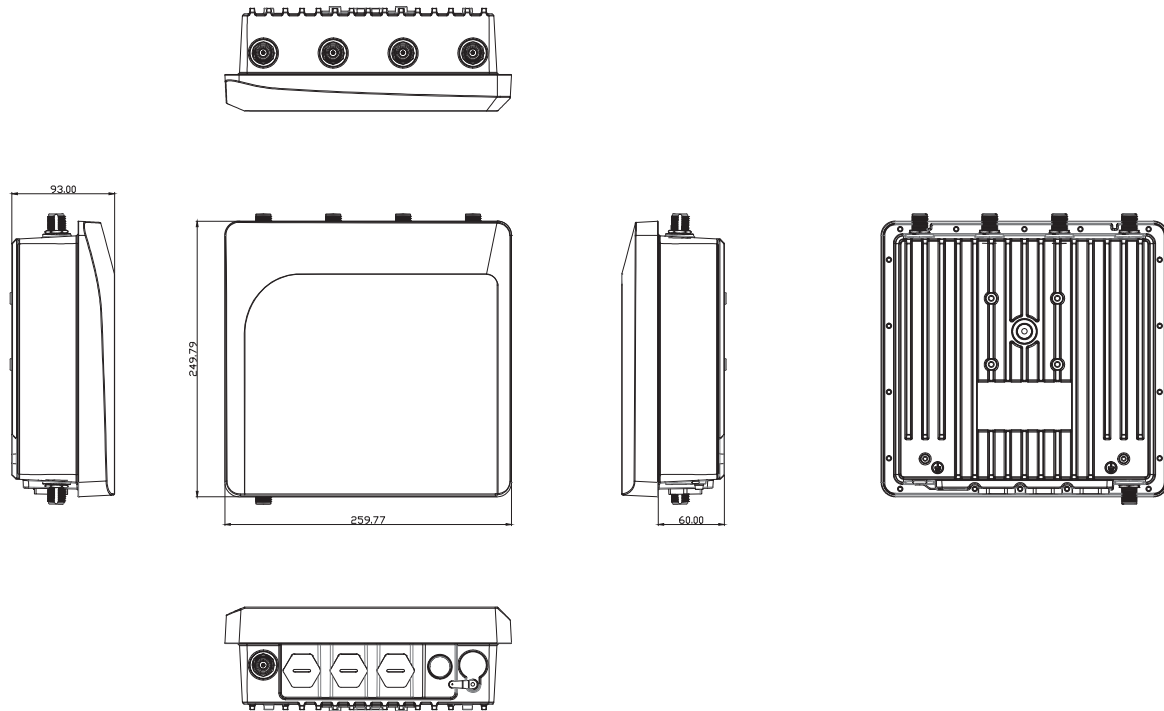

Environment Protection

- Operating temperature: -40~75°C (altitude : up to 3000m)
- Storage temperature: -40~80°C
- Humidity: 0% to 95% maximum (non-condensing)
- Vibration: random 0.3g

Certification

- UL 60950-1; 60950-22
- Radio approvals
 - FCC Part 15.247, 15.407 - EN 300 328 - EN 301 893
- EMI and susceptibility - FCC Part 15.107, 15.109 - EN 301 489-1, -17

Anti-Explosive Certification

- UL: Class I, Division 2, Groups A, B, C and D, T4
- ATEX: Class I, Zone 2; Ex nA II, T4

ISA100 Capabilities

| Wireless Communication Interface Specifications | |
|---|---|
| Standard IEEE | 802.15.4 |
| Data Rate | 250 kbps |
| Modulation | Q-PSK |
| Spread Spectrum | DSSS |
| RF Output Power | Max +15 dBm |
| Sensitivity | -95 dBm |
| Connector | N type |
| Antenna | 2 dBi@ 2.4GHz |
| Performance Parameters | |
| Scalability | NIO 200IAG: 100 field instruments |
| | NIO 200IDG: 200 field instruments, 20 subnets |
| | NIO 200IDR: 50 field instruments |
| | NIO 200HAG: 250 field instruments |
| Mesh Network Depth | 3 hops |
| Field Device Join Time | As low as 20 seconds |

| | |
|----------------|--|
| Reporting Rate | ISA100: 1, 5, 10, 20, 30 and 60 seconds; 10 devices publishing/second |
| | WirelessHART: 8, 16, 32 secs and 1-60 minutes; 10 devices publishing/second |

Ordering Information

| | ISA100 | WirelessHART |
|-----------------------------|-------------------------------------|-------------------------------------|
| All-in-One Gateway | NIO 200IAG-US P/N: 10T00020008X0 | NIO 200HAG-EU P/N: 10T00020010X0 |
| Distributed Gateway | NIO 200IDG-US P/N: 10T00020009X0 | - |
| Distributed Backbone Router | NIO 200IDR-US P/N: 10T00020004X0 | - |

Optional Accessories

- ♦ **P/N: 5040210012X00**
SIMPLE WALL MOUNT KIT VER: A SIN SUPER CIRCLE
- ♦ **P/N: 5040410110X00**
POLE MOUNT FOR NIO200 VER: A SIN SUPER CIRCLE 92x228x90mm
SECC=2.0t WHITE
- ♦ **P/N: 7A00000066X00**
Antenna arrester, DC-6 GHz N-MALE TO N-FEMALE
- ♦ **P/N: 603ANT0012X00**
Dual Polarization-Directional Antenna for 5 GHz 20dBi
- ♦ **P/N: 603ANT0009X00**
Directional Antenna 2300~2700 MHz 16~17 dBi
- ♦ **P/N: 603ANT0010X00**
Directional Sector Antenna 2400~2500 MHz 14±0.5 dBi
- ♦ **P/N: 603ANT0013X00**
Directional Sector Antenna 5150~5875 MHz 15±0.5 dBi